

90/140

MOŽNOST 1

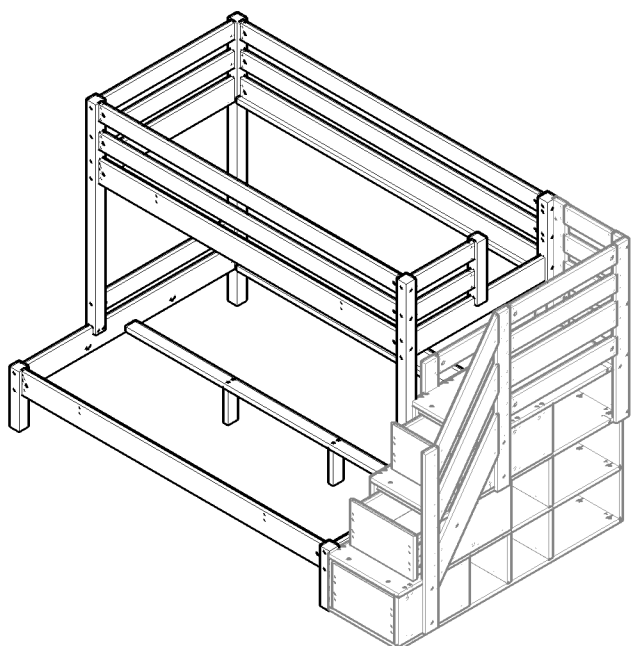

MOŽNOST 2

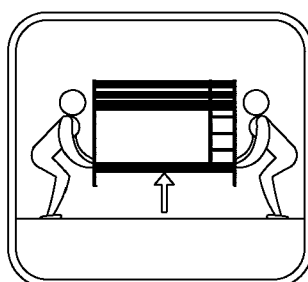
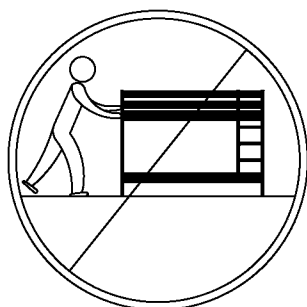
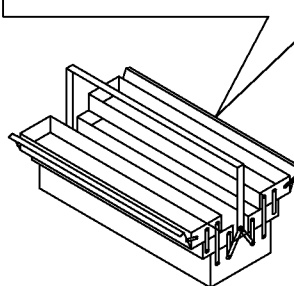
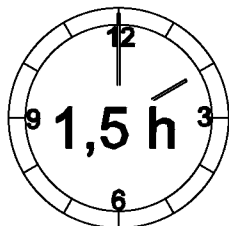
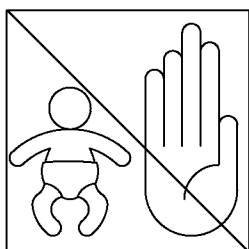
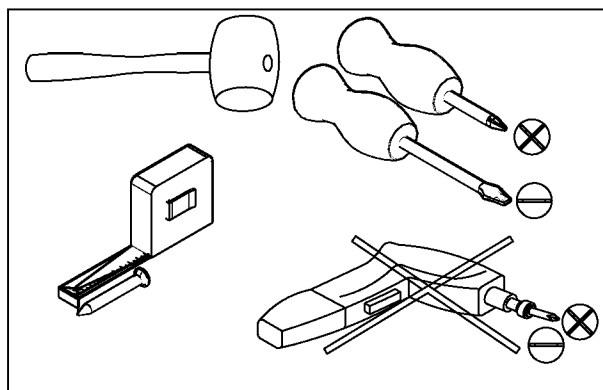
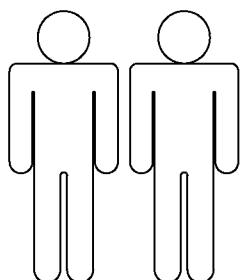
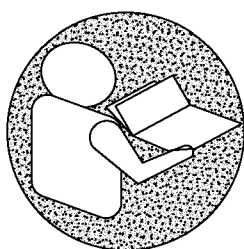
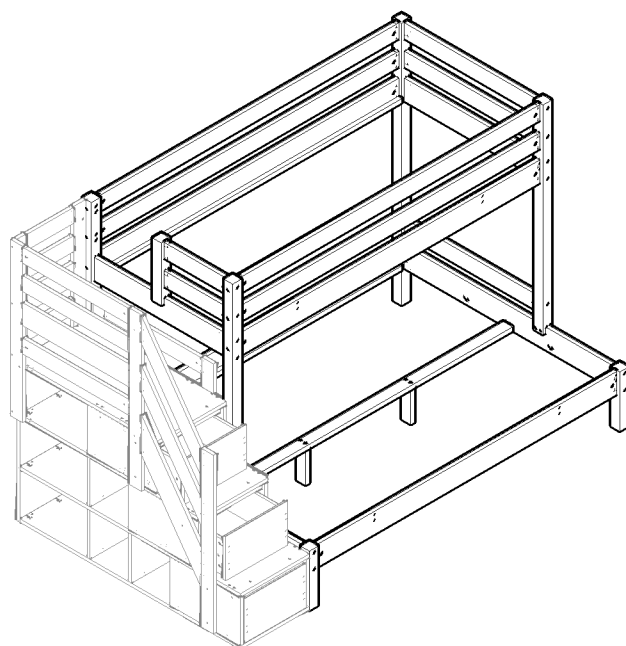

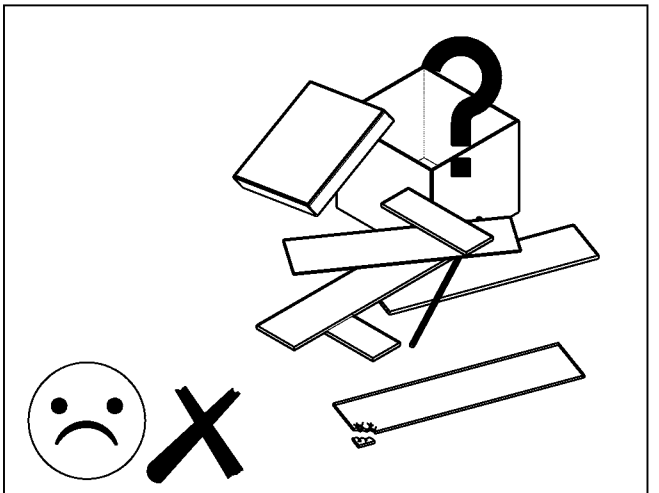
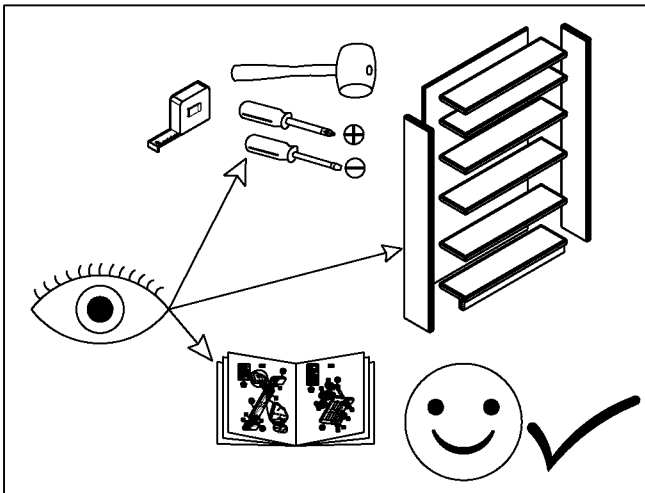
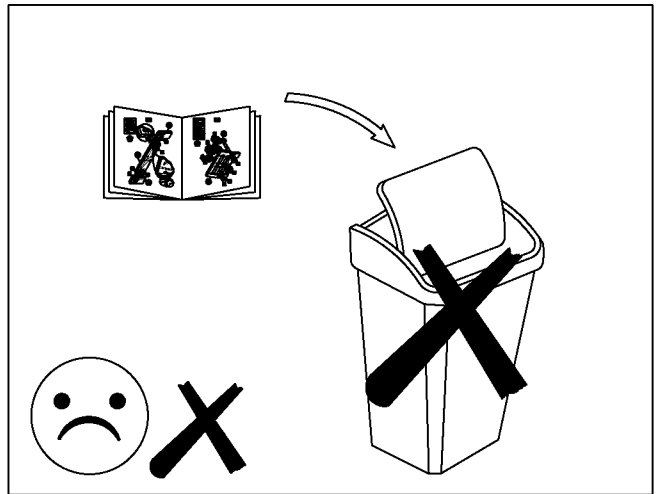
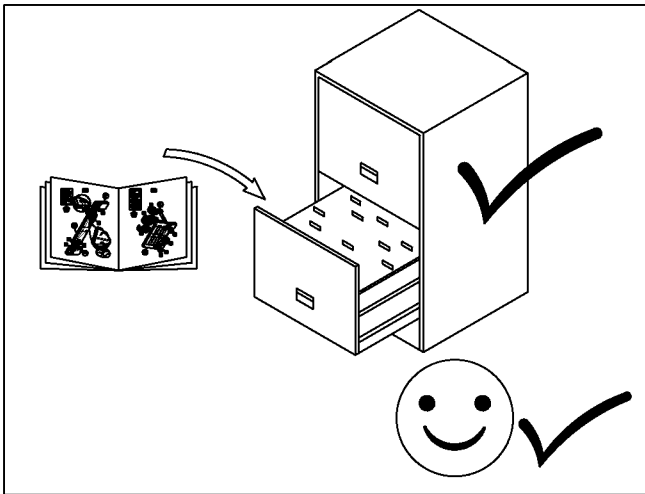
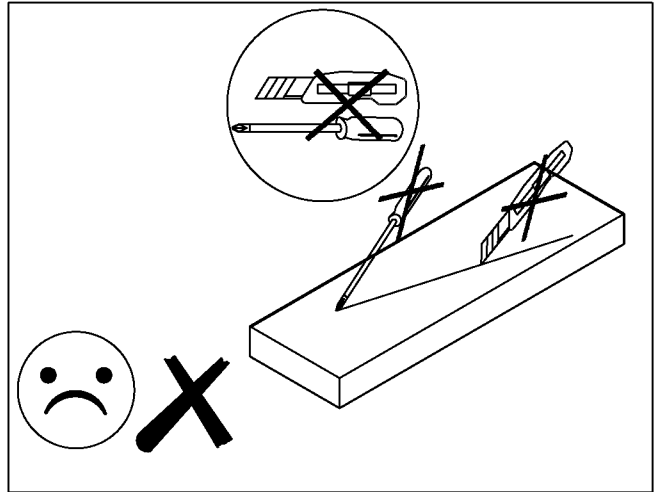
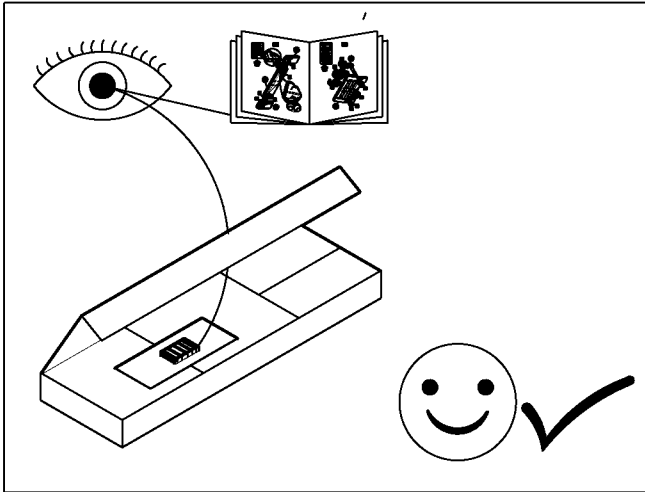
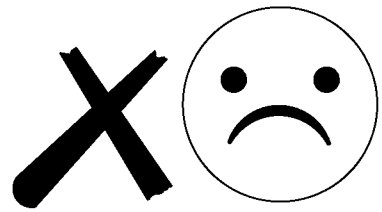
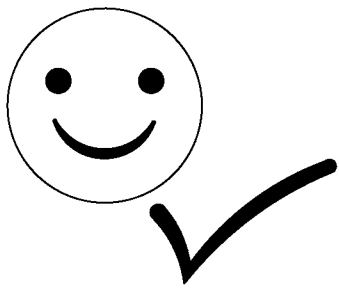

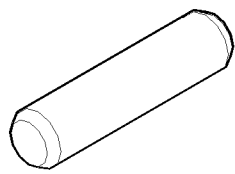
K7

x 54

Ø10 x 50

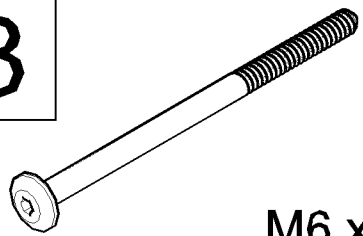
J13

x 16

M6 x 100

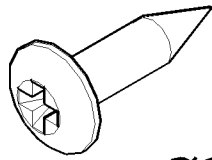
S3

x 10

Ø3,5 X 16

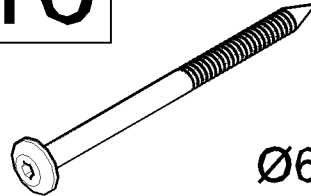
S16

x 28

Ø6,3 x 110

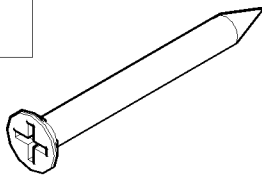
S8

x 4

Ø4 X 60

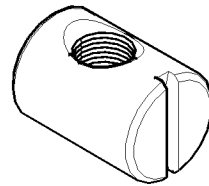
H4

x 16

Ø10/M6 x 13

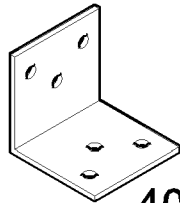
B3

x 2

40x40x40

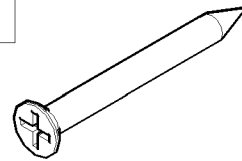
S7

x 6

Ø4 x 50

D11

x4

Ø8

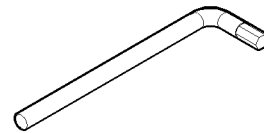
F2

HEX 4 mm

D9

x6

Ø10

Q1

x1

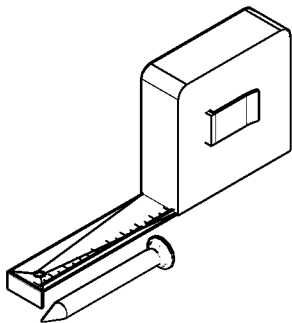

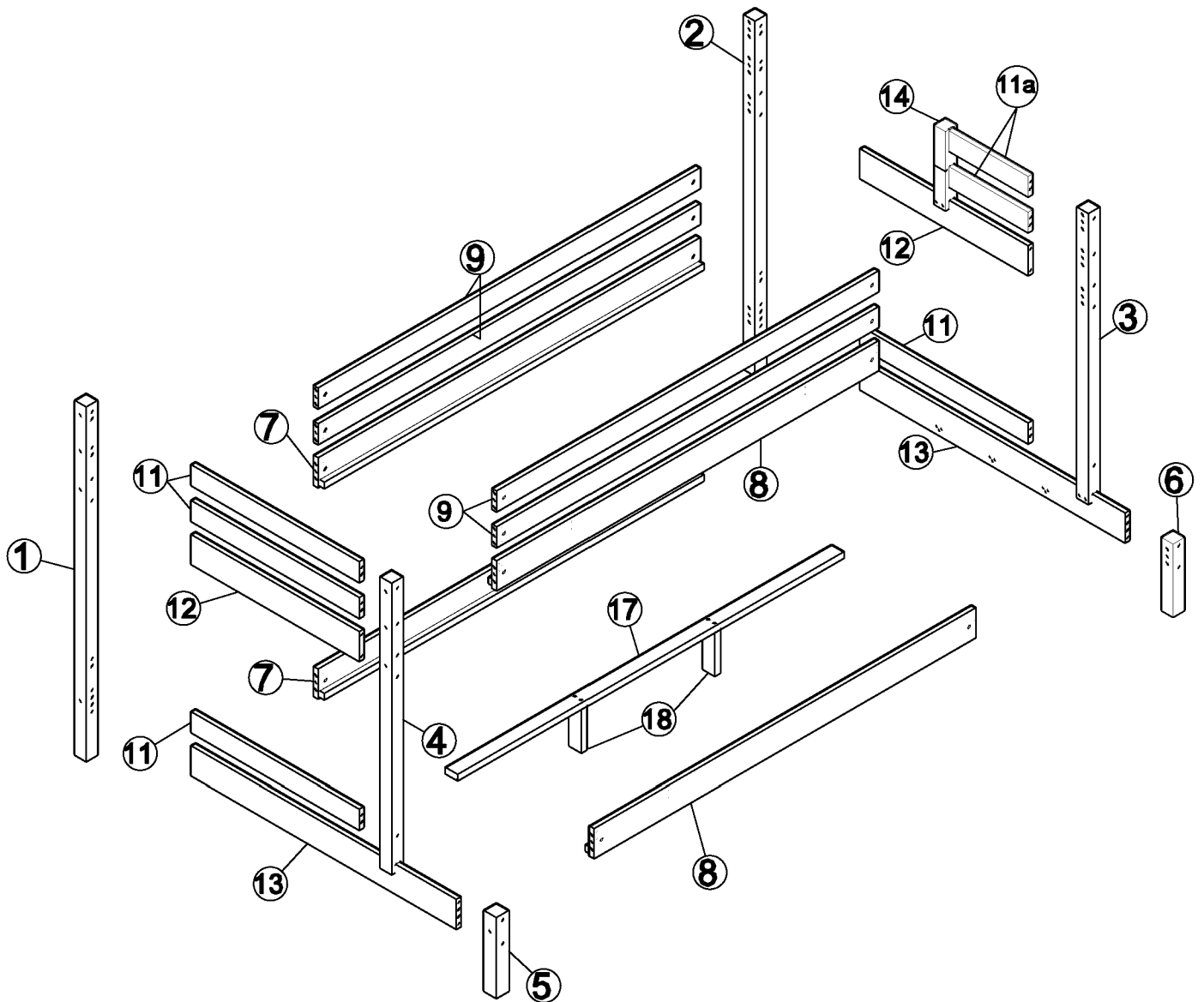

PŘEDMĚT ČÍSLO	POČET KS	DIMENZE LXBX T(MM)	✓	PŘEDMĚT ČÍSLO	POČET KS	DIMENZE LXBX T(MM)	✓
1	1	1590 X 56 X 56		9	4	1964 X 90 X 20	
2	1	1590 X 56 X 56		11a	2	408 X 90 X 20	
3	1	1295 X 56 X 56		11	4	864 X 90 X 20	
4	1	1295 X 56 X 56		12	2	864 X 130 X 20	
5	1	335 X 56 X 56		13	2	1364 X 130 X 20	
6	1	335 X 56 X 56		14	1	352 X 56 X 56	
7	2	1964 X 130 X 20		17	1	1985 X 60 X 25	
8	2	1964 X 130 X 20		18	2	205 X 60 X 25	

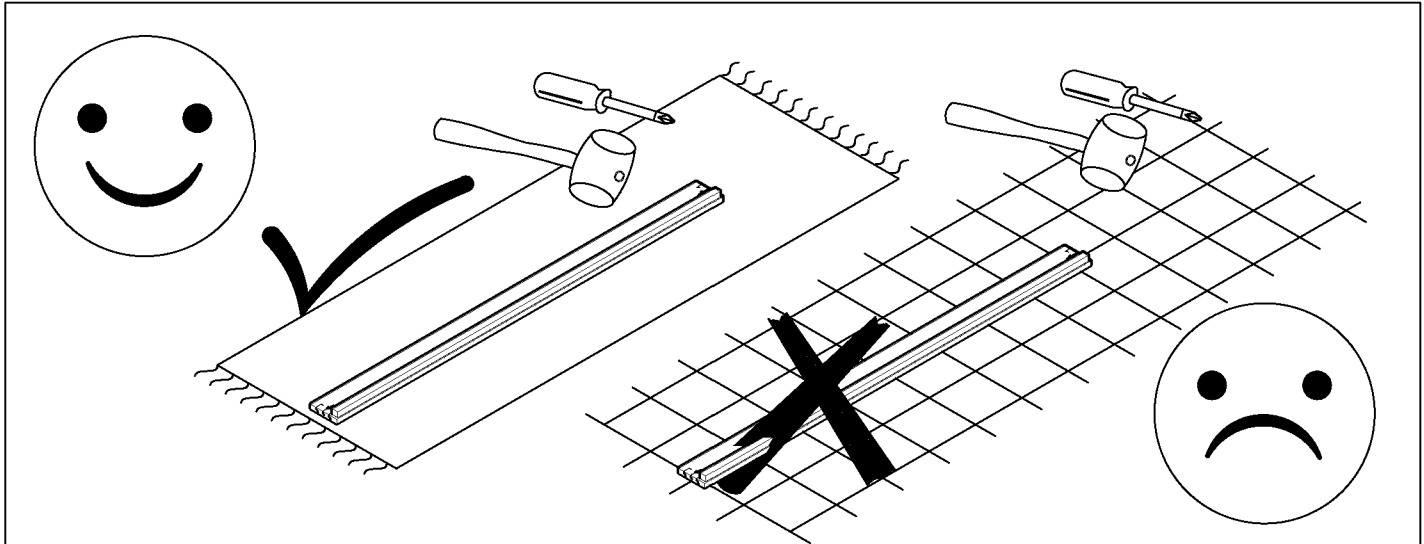

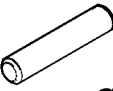
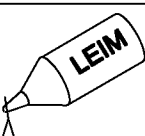
K7		x 8
		Ø10 X 50
Q1		x 1

1

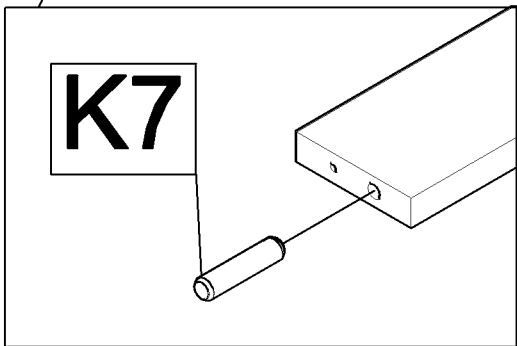
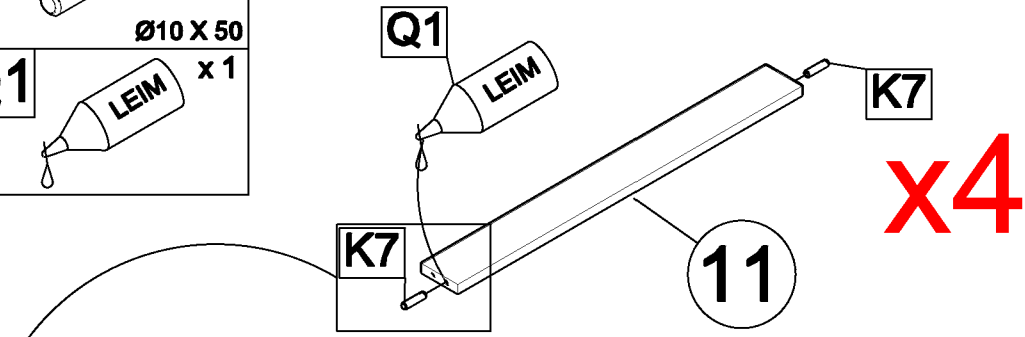

2

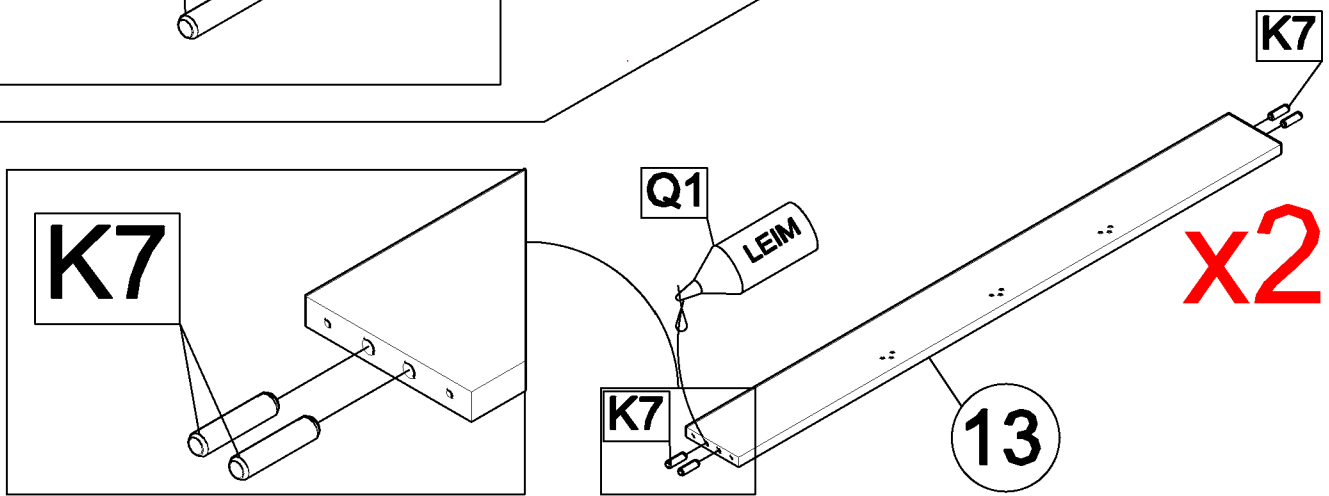

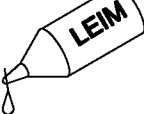
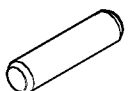
Q1		x 1	K7		x 8
					Ø10X 50

MOŽNOST 1

6a/21

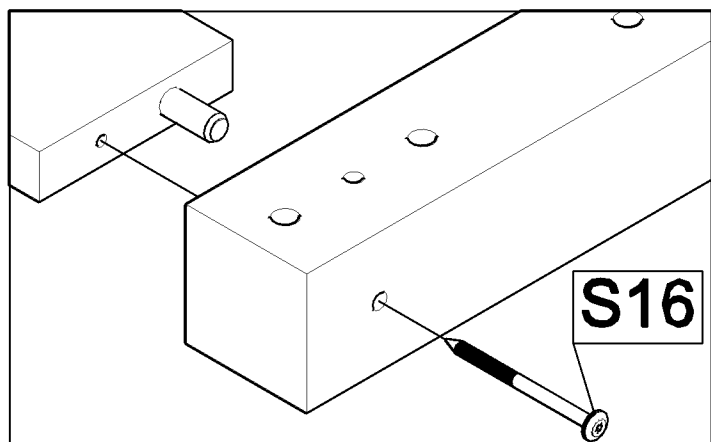
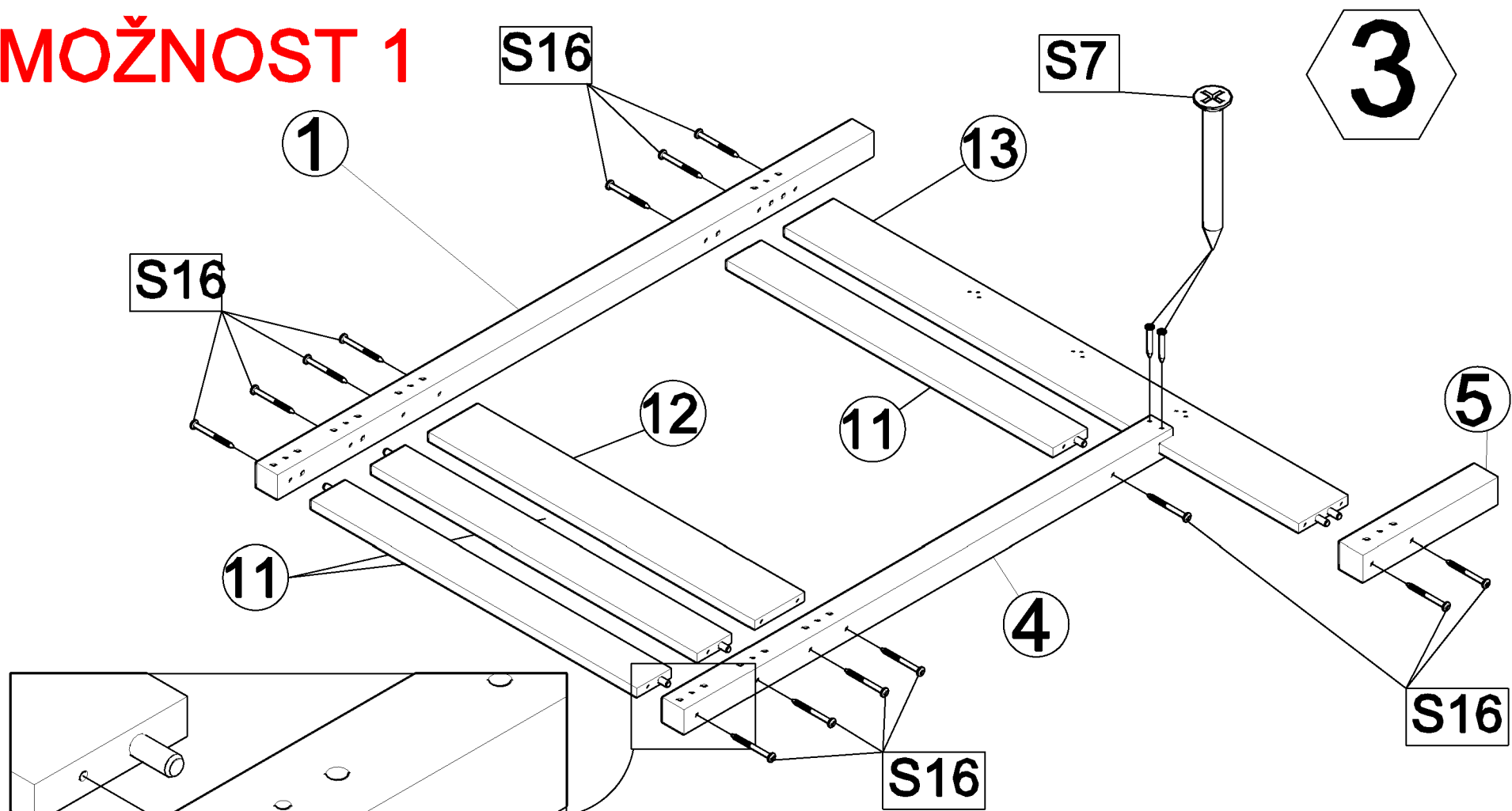

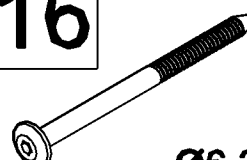
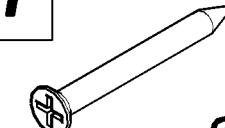
S16	x 14	S7	x 2
	$\text{Ø}6,3 \times 110$		$\text{Ø}4 \times 50$

MOŽNOST 1

4

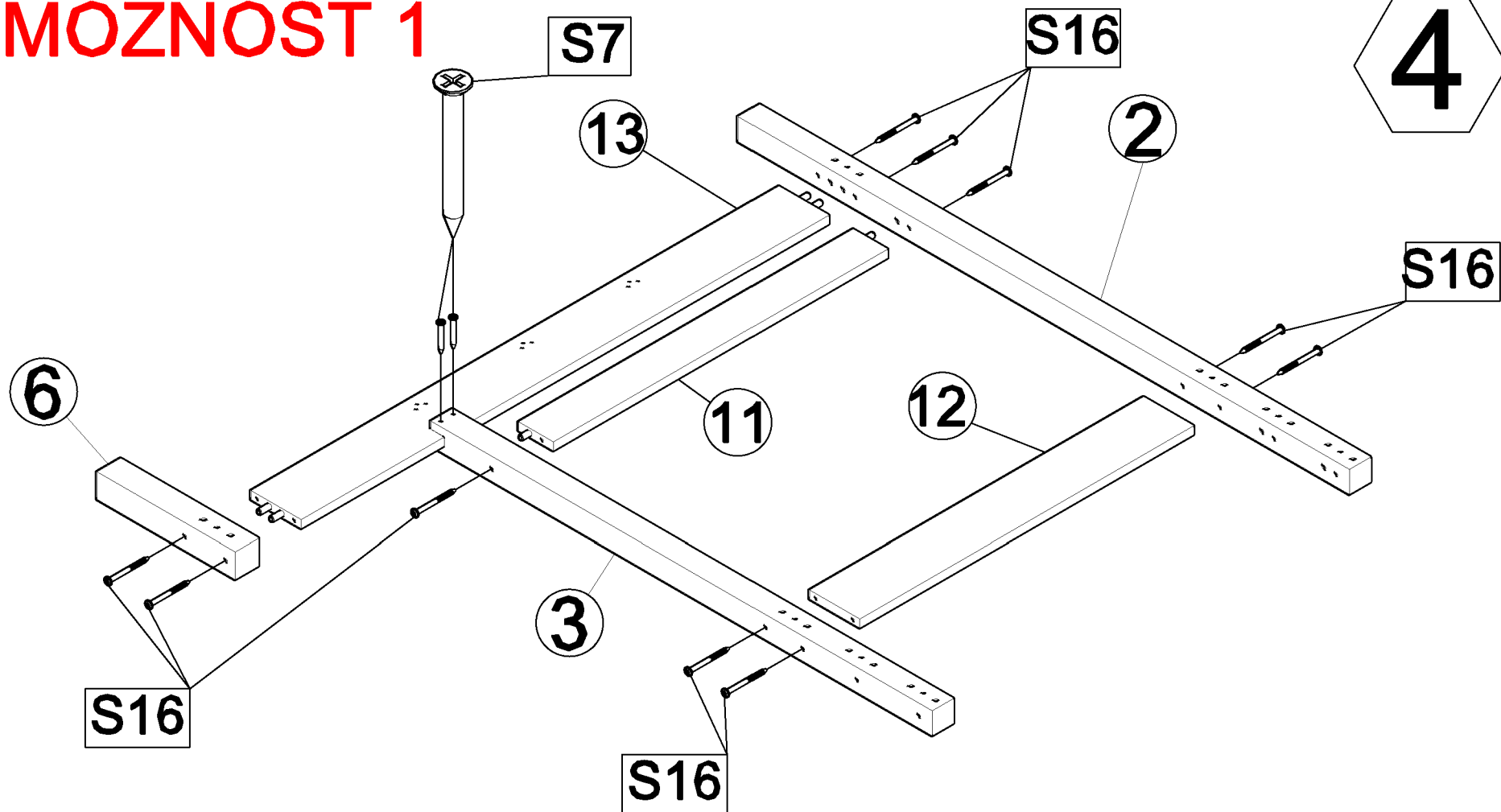

7a/21

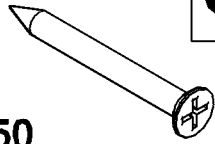
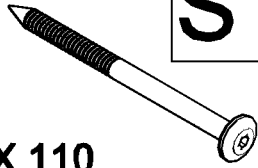
x 2	S7	x 10	S16
			
Ø4 X 50		Ø6,3 X 110	

MOŽNOST 2

3a

8a/21

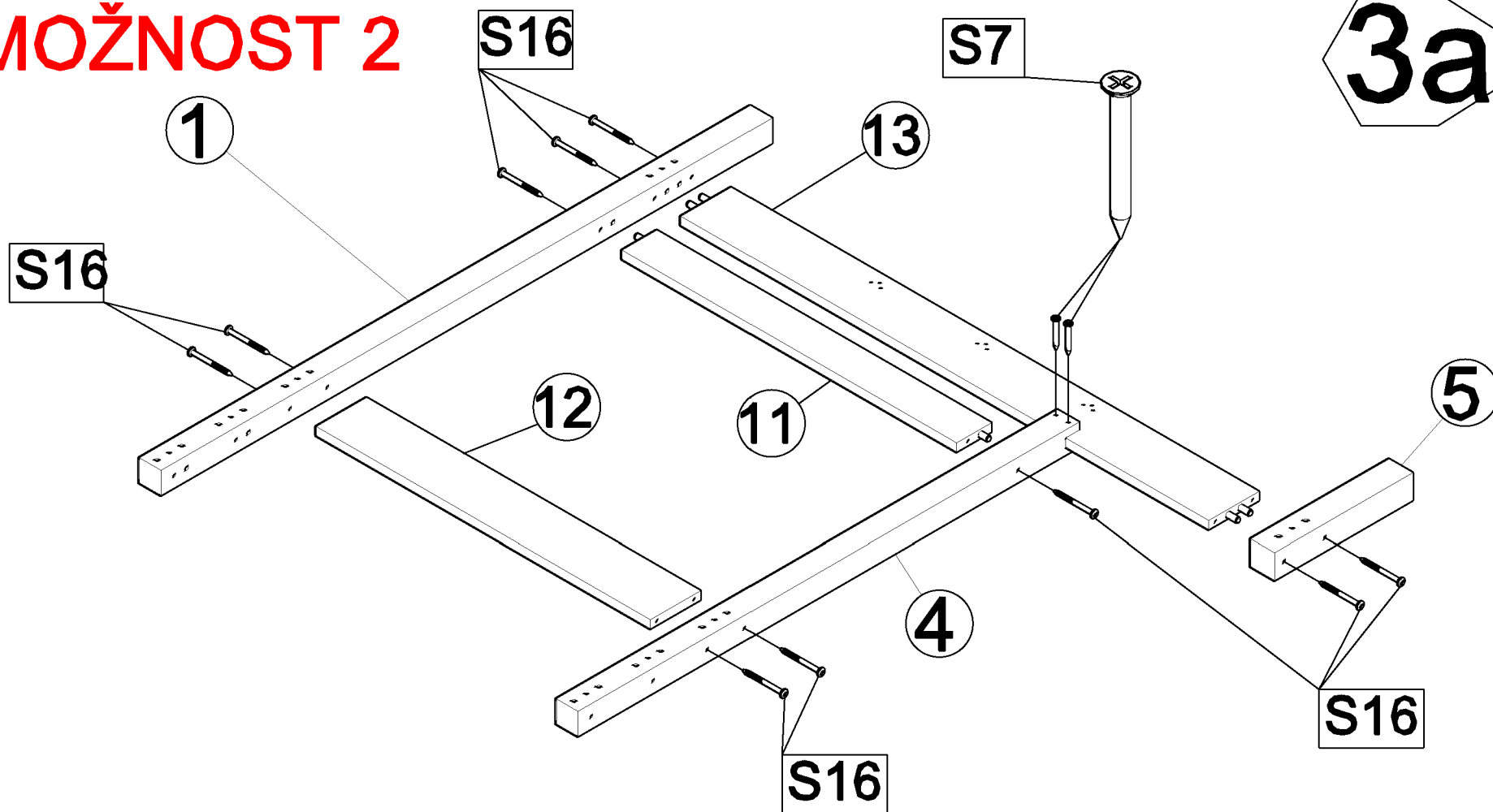

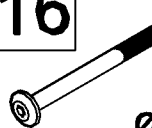
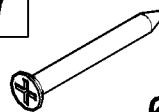

S16	x 10	S7	x 2
	Ø6,3 X 110		Ø4 X 50

MOŽNOST 2

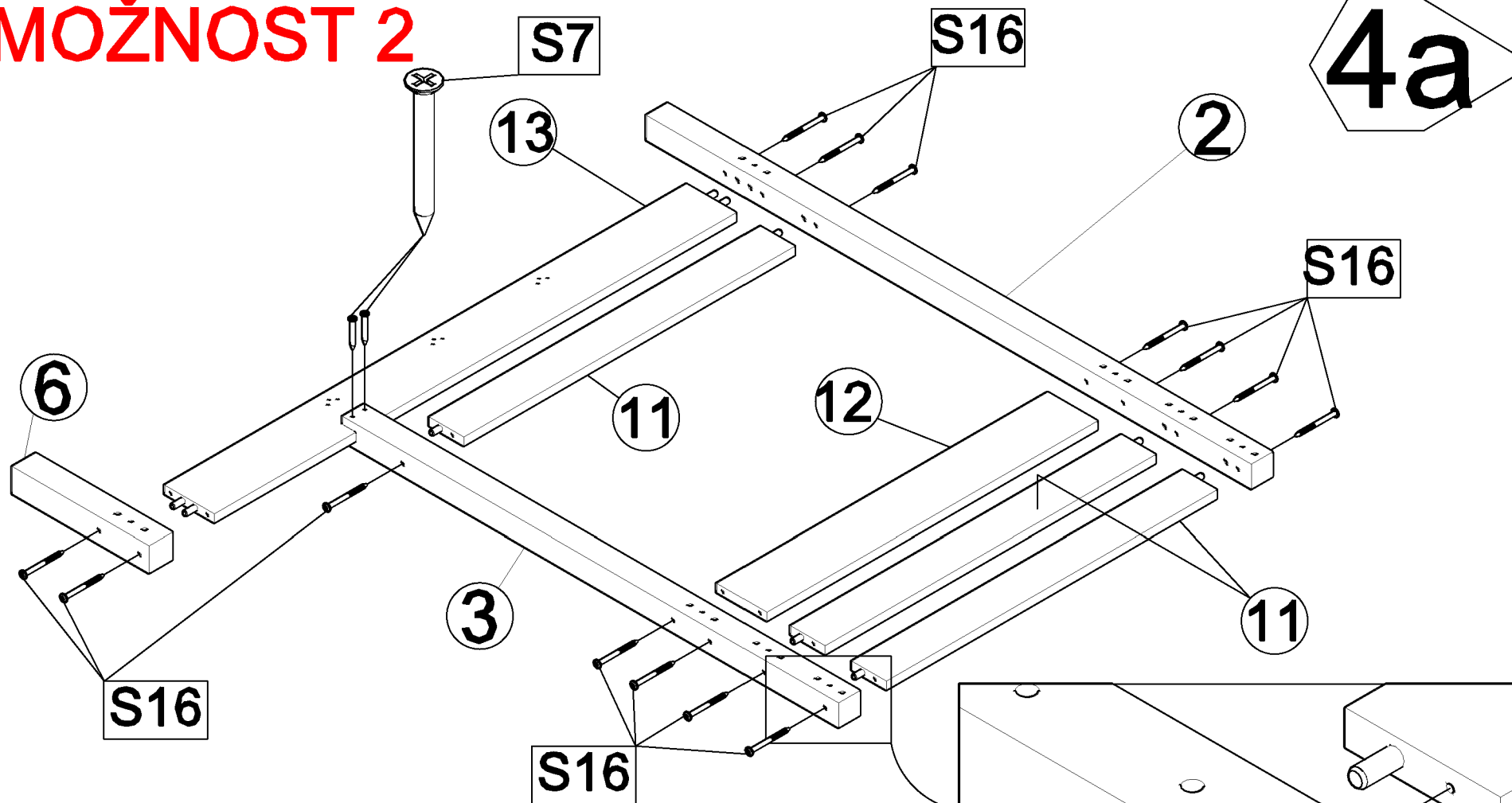

4a

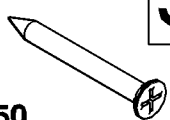
9a/21

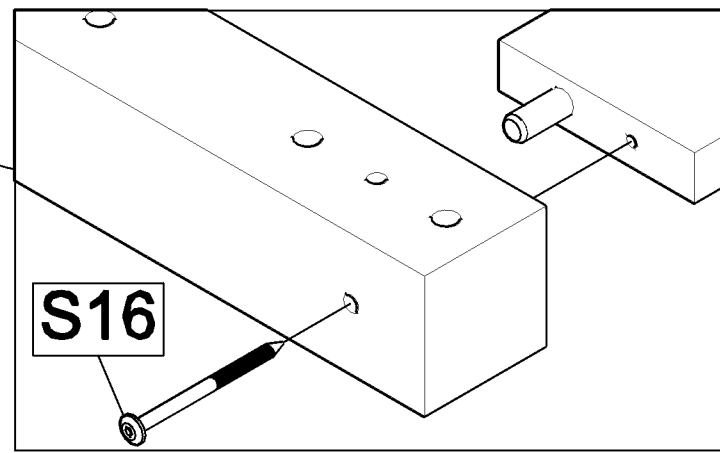

x 2	S7	x 14	S16
Ø4 X 50		Ø6,3 X 110	

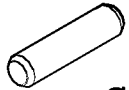

K7	x 8	Q1	x 1
			
Ø10X 50		LEIM	

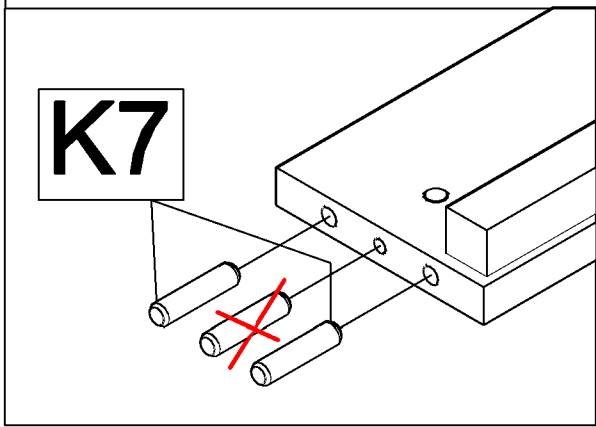
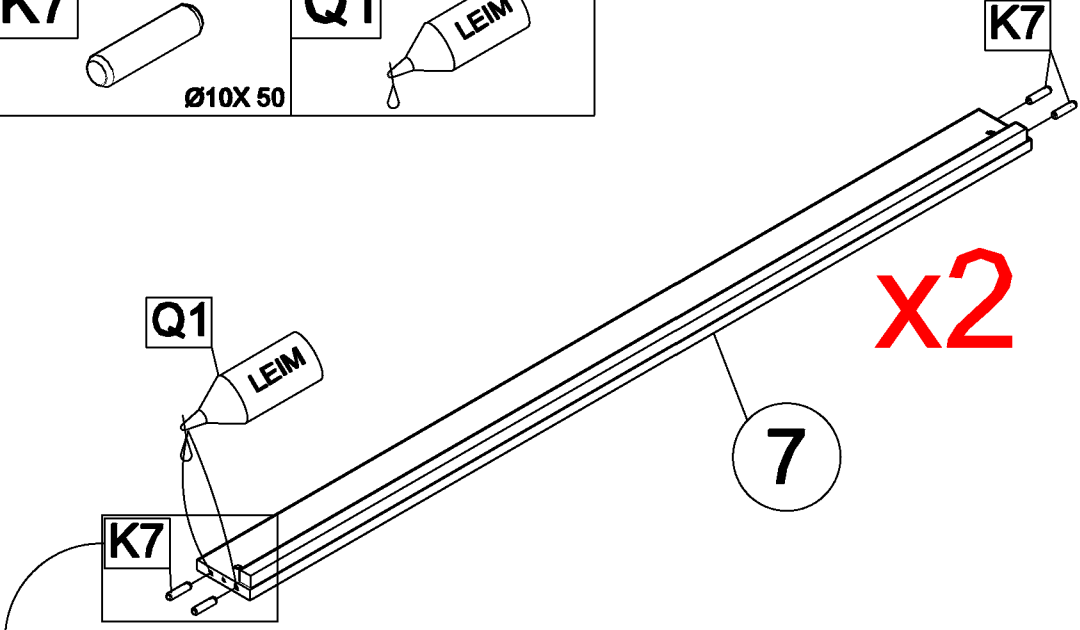

5

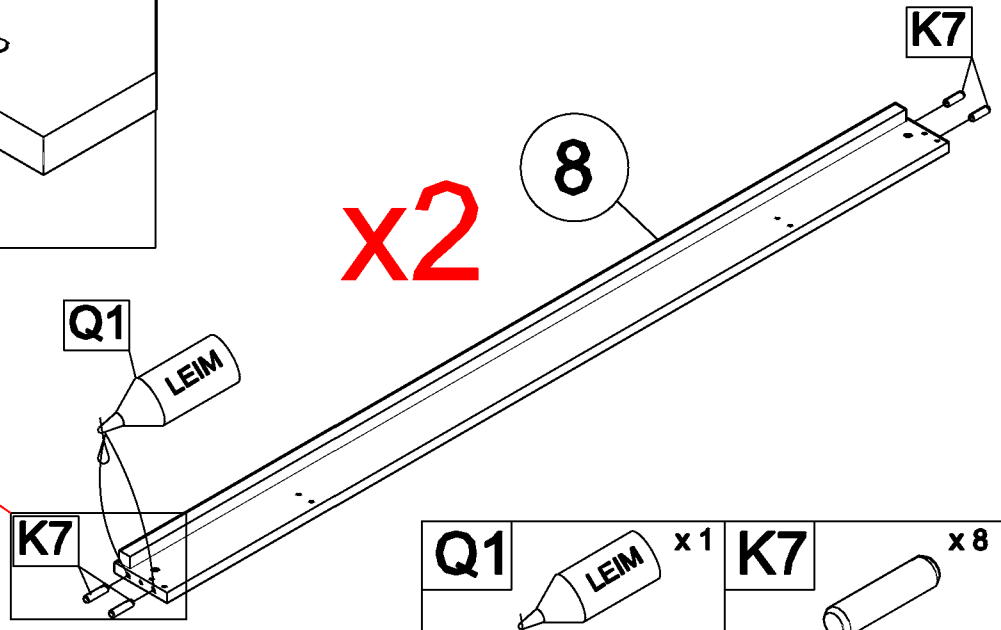
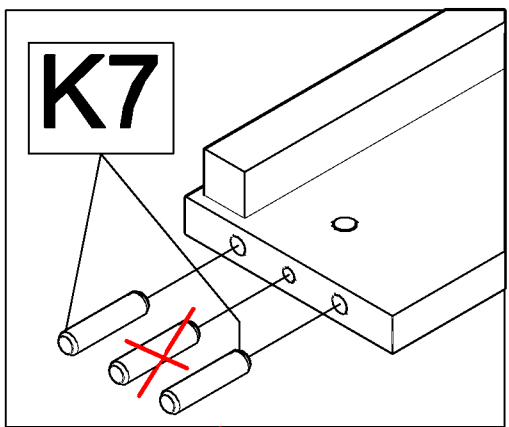

6

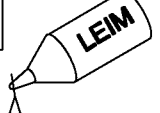
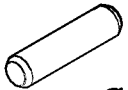

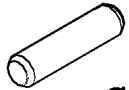
Q1	x 1	K7	x 8
			
LEIM		Ø10X 50	

K7	x 16	Q1	x 1
			
Ø10X 50			

7

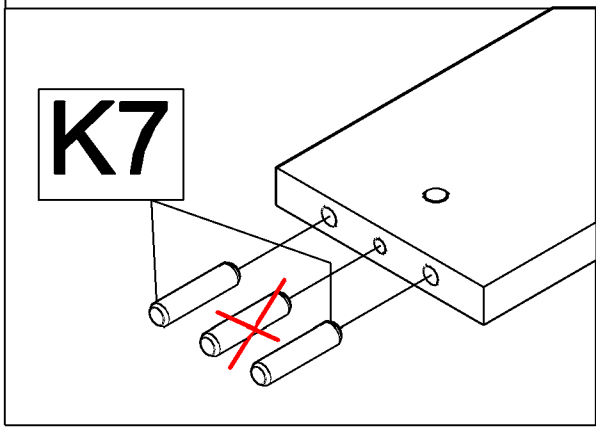
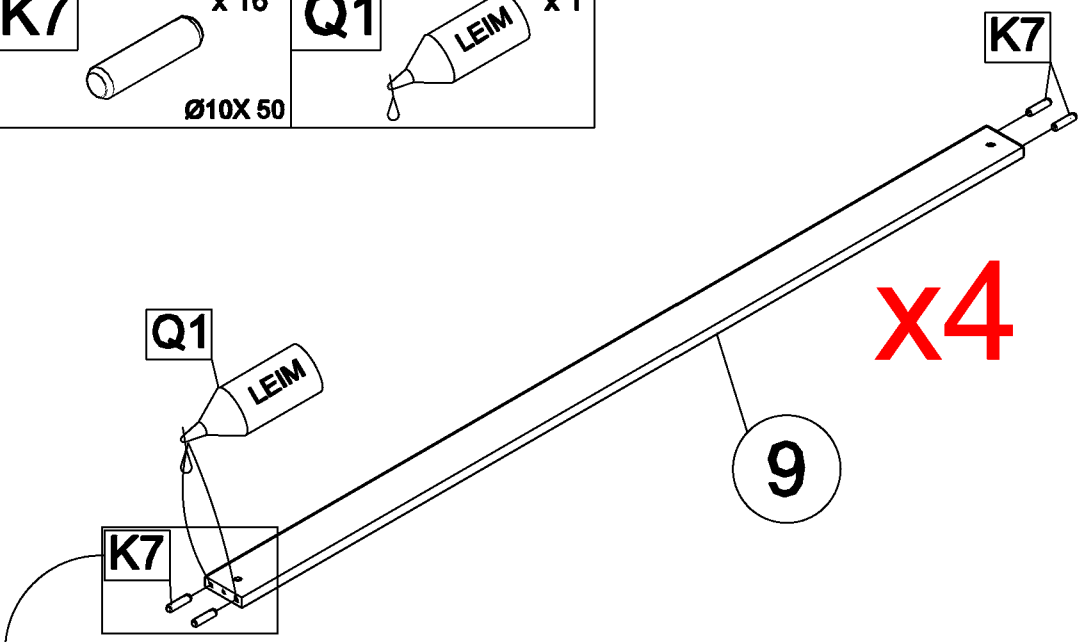

8

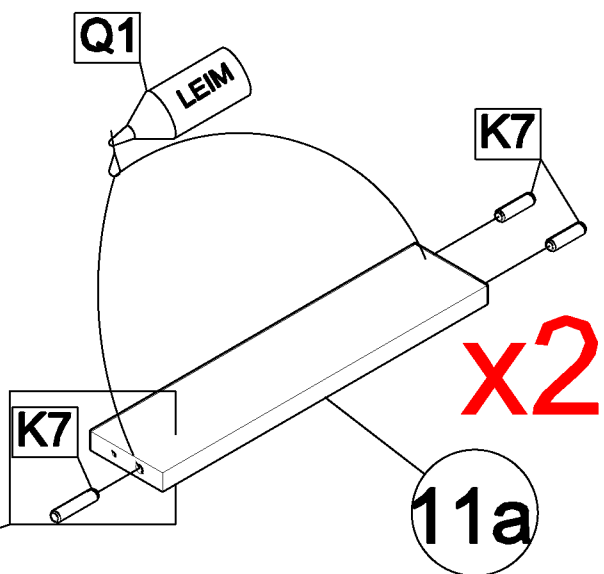
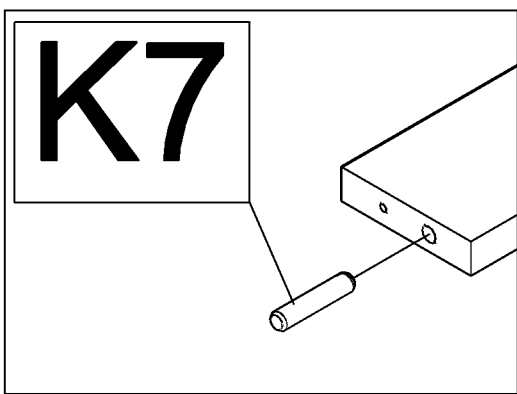

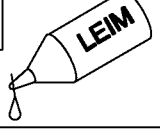
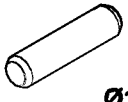
Q1	x 1	K7	x 6
			
		Ø10X 50	

J16

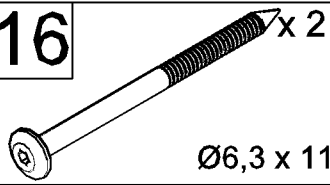

F2

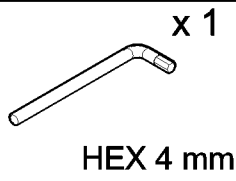

MOŽNOST 1

9

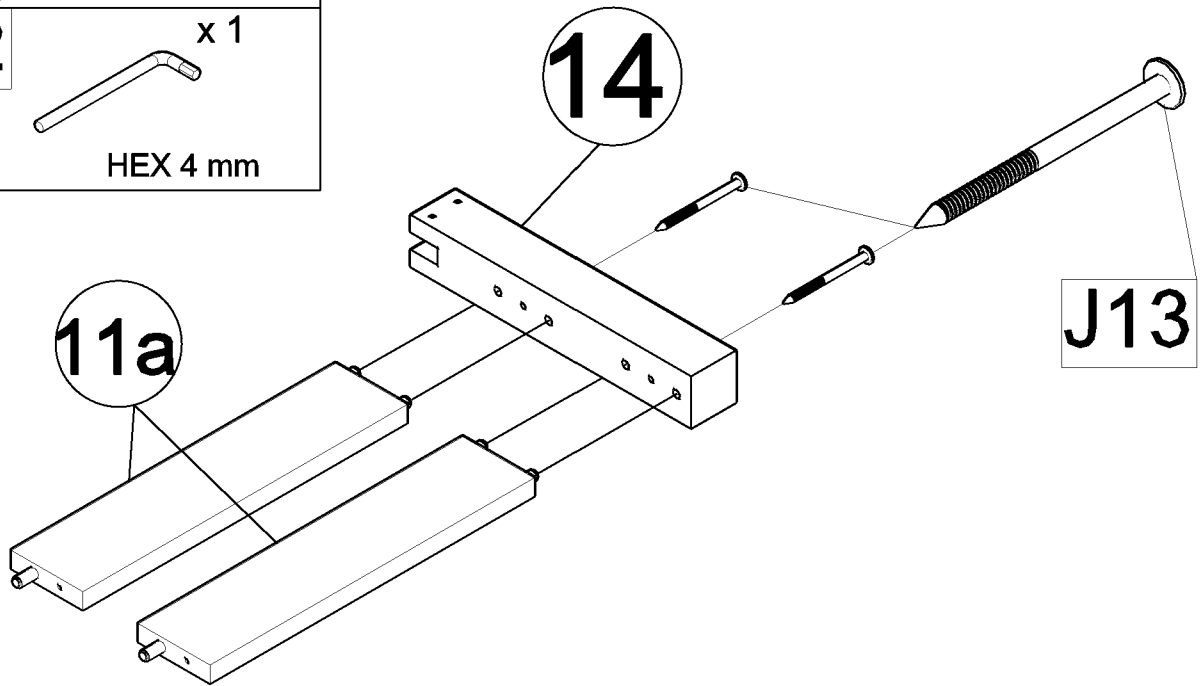

MOŽNOST 2

9a

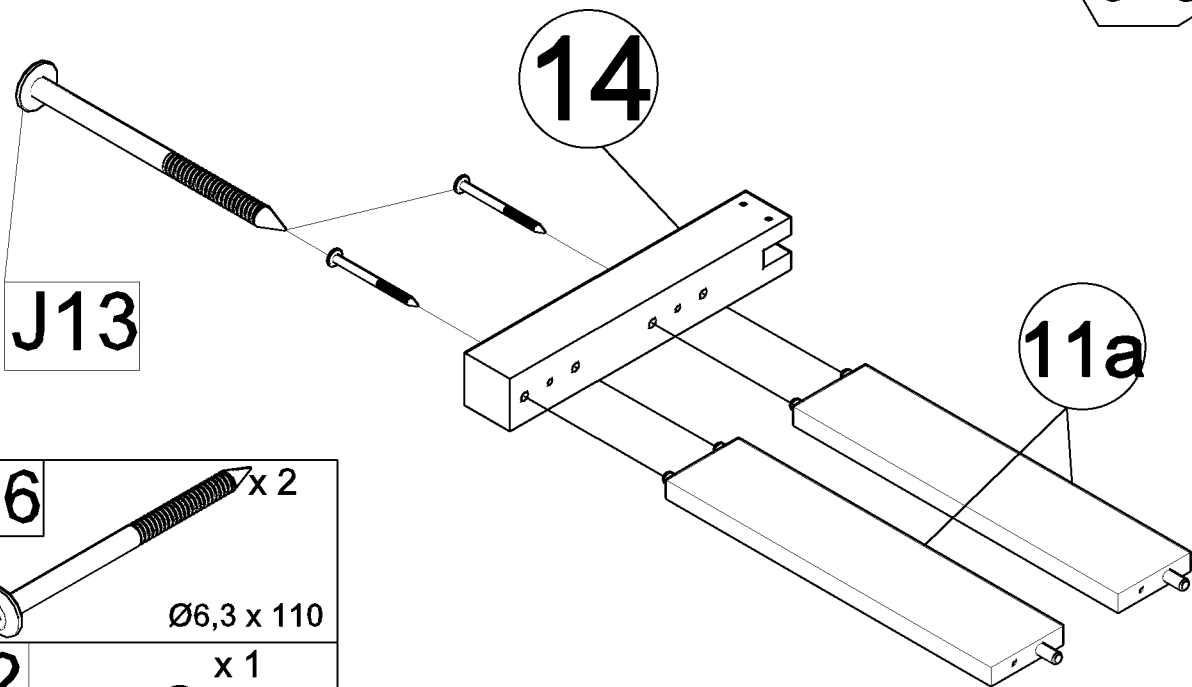

J16

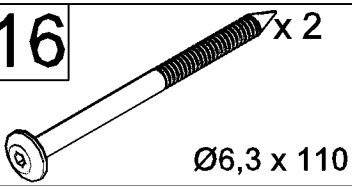

F2

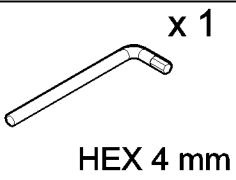

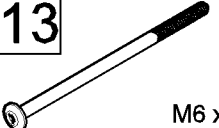
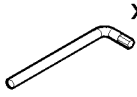
H4		x 8
		Ø10X 13
J13		x 8
		M6 x 100
F2		x 1
		HEX 4 mm

MOŽNOST 1

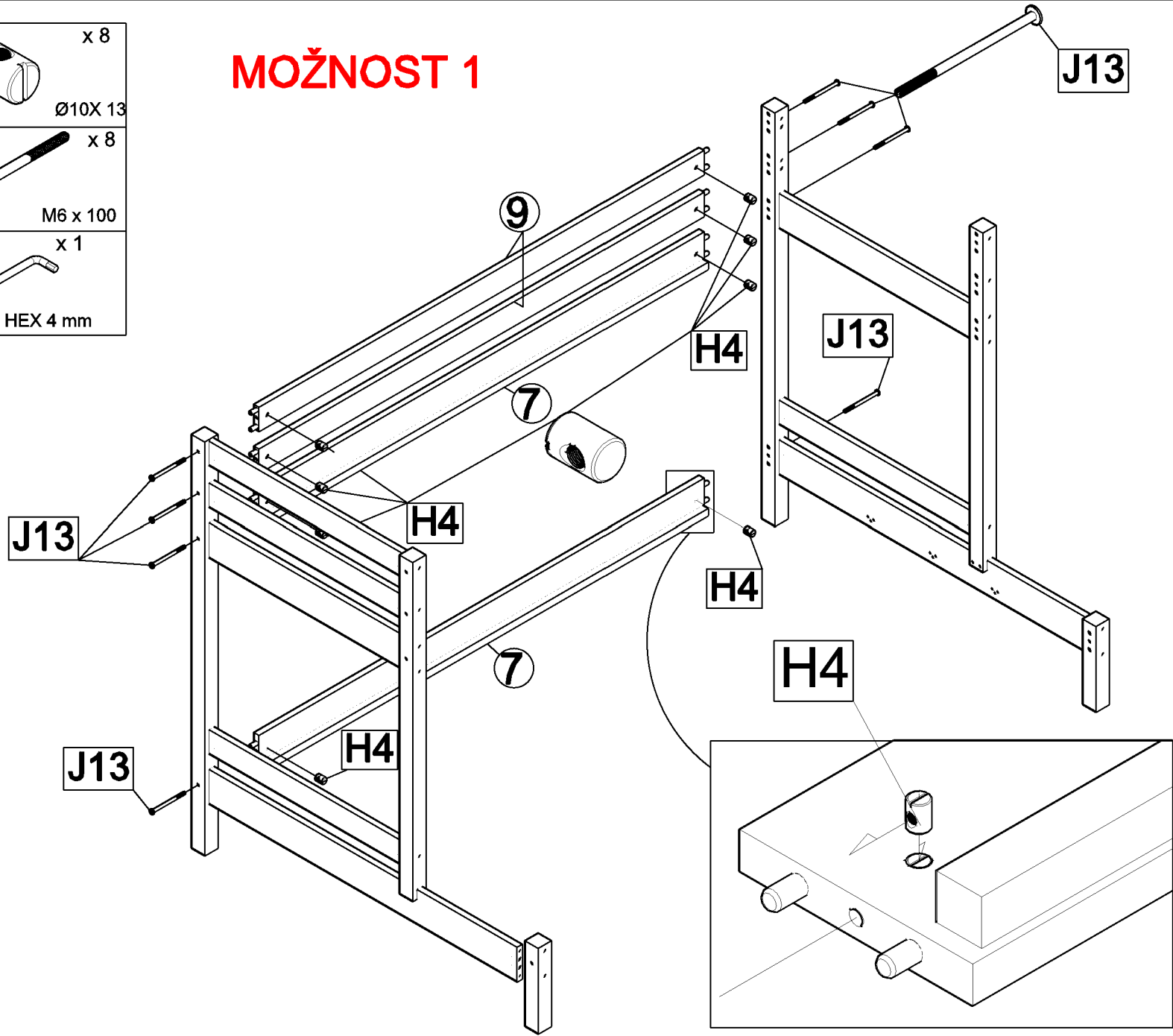

11

13a/21

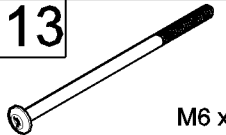

11a

MOŽNOST 2

H4		x 8
J13		x 8
F2		x 1
Ø10X 13		
M6 x 100		
HEX 4 mm		

14a/21

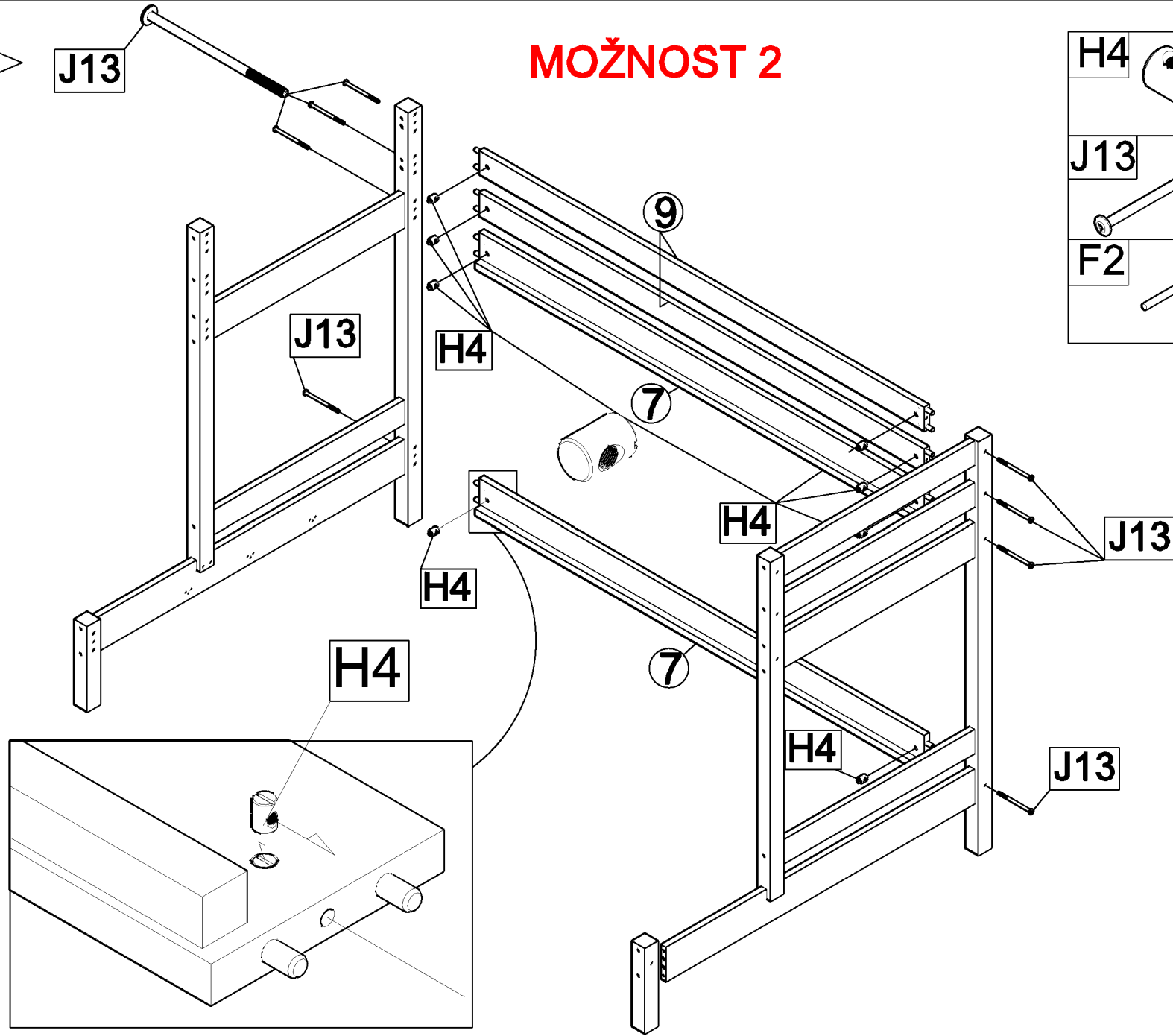

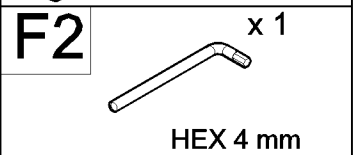
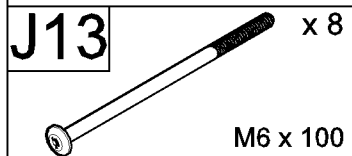
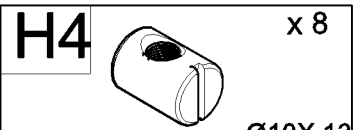

MOŽNOST 1

12

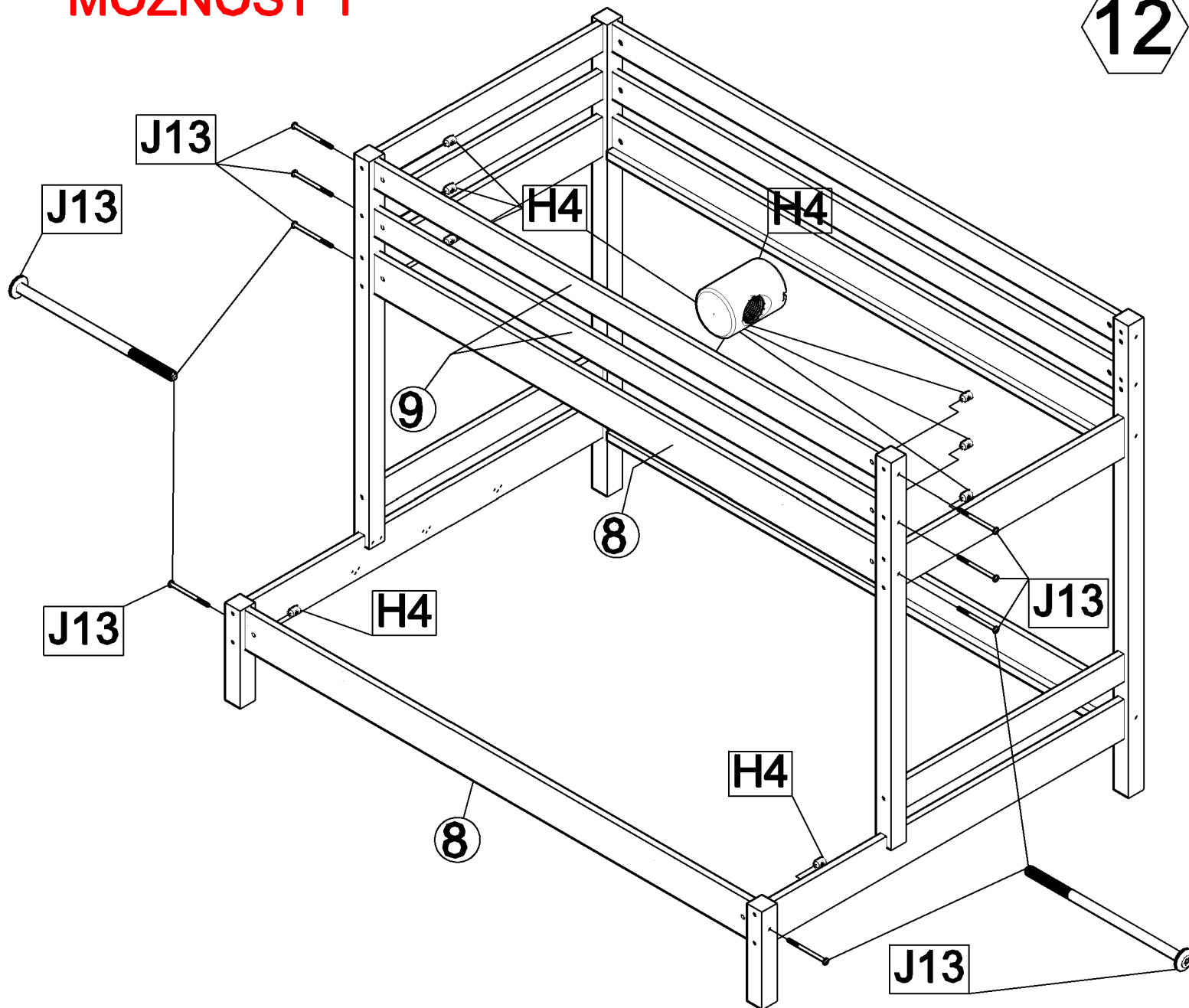





15a/21

12a

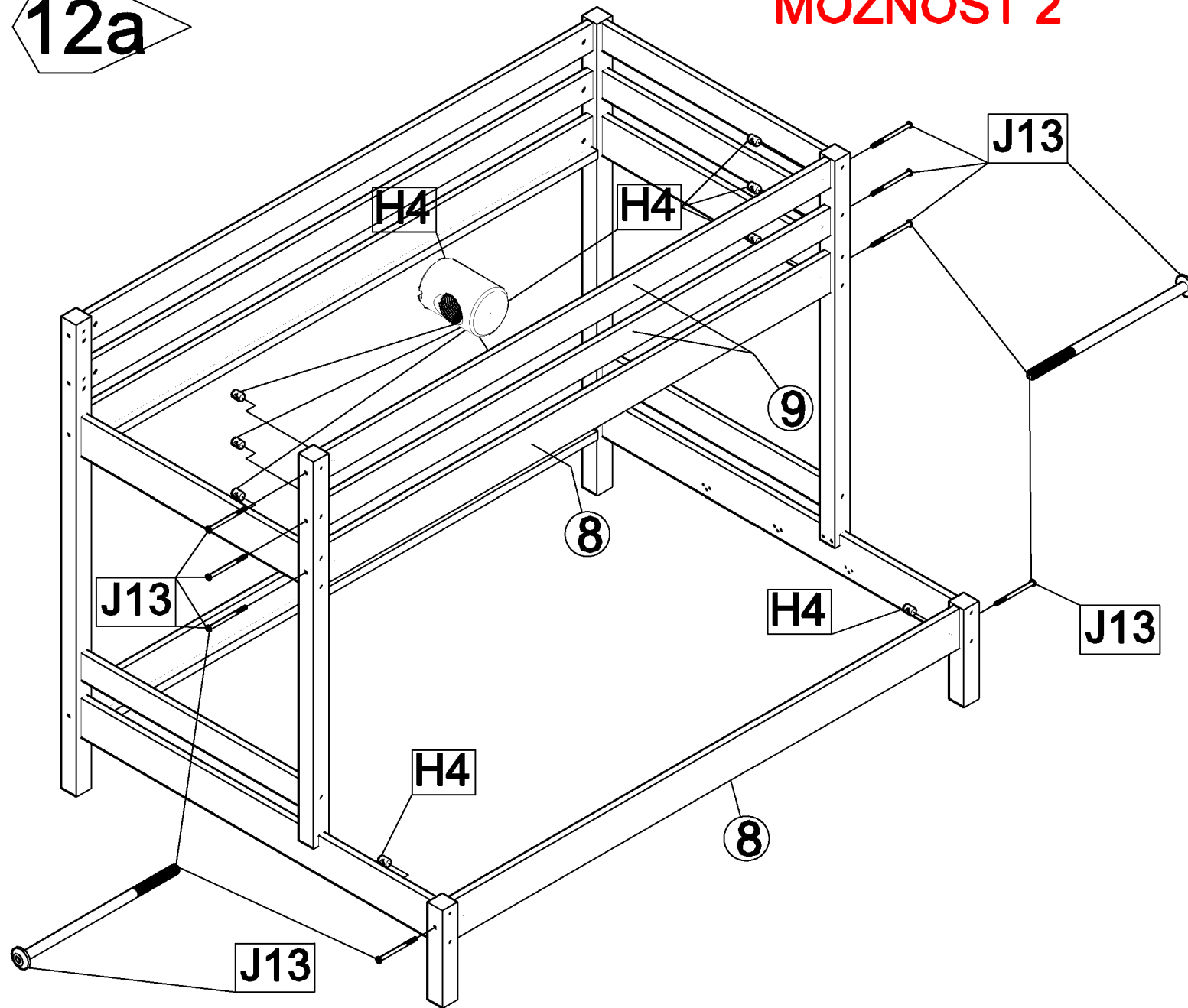
MOŽNOST 2

16a/21

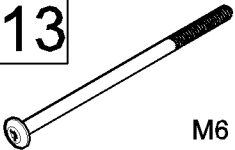

H4		x 8
		Ø10X 13
J13		x 8
		M6 x 100
F2		x 1
		HEX 4 mm

17/21

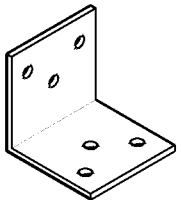
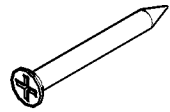
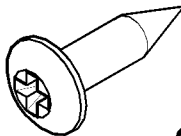
B3		x 2
	40x40x40	
S8		x 4
	Ø4x 60	
S3		x 6
	Ø3,5x 16	

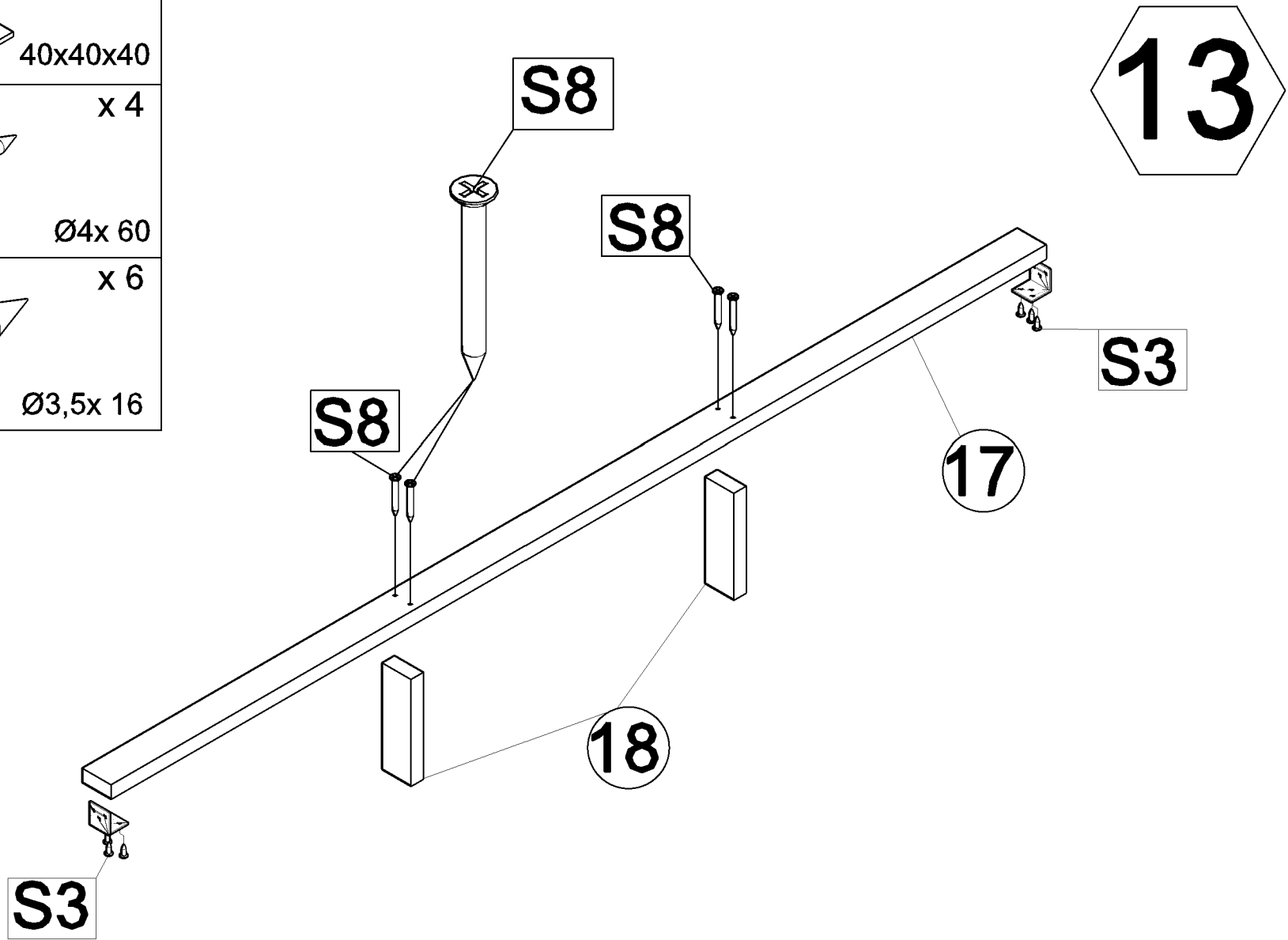

MOŽNOST 1

14



6+

Maximální umístění
horní části matrace

Maximální tloušťka
matrace 18 cm

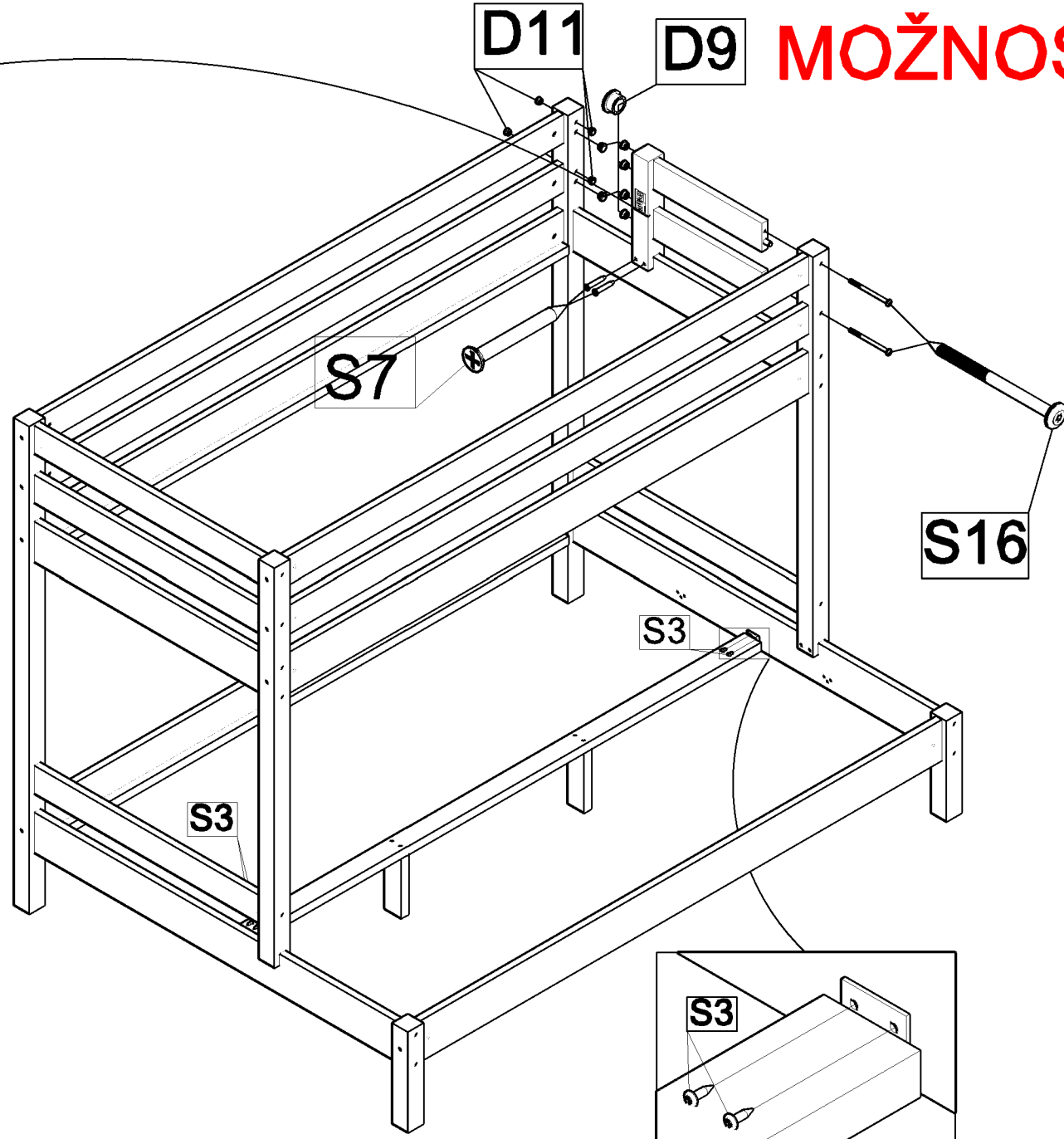

18a/21

- S16** x 2
Ø6,3 x 110
- S7** x 2
Ø4 x 50
- D11** x 4
Ø8
- D9** x 6
Ø10
- S3** x 4
Ø3,5 x 16

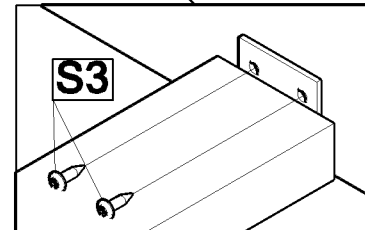

MOŽNOST 2

D9 D11

14a

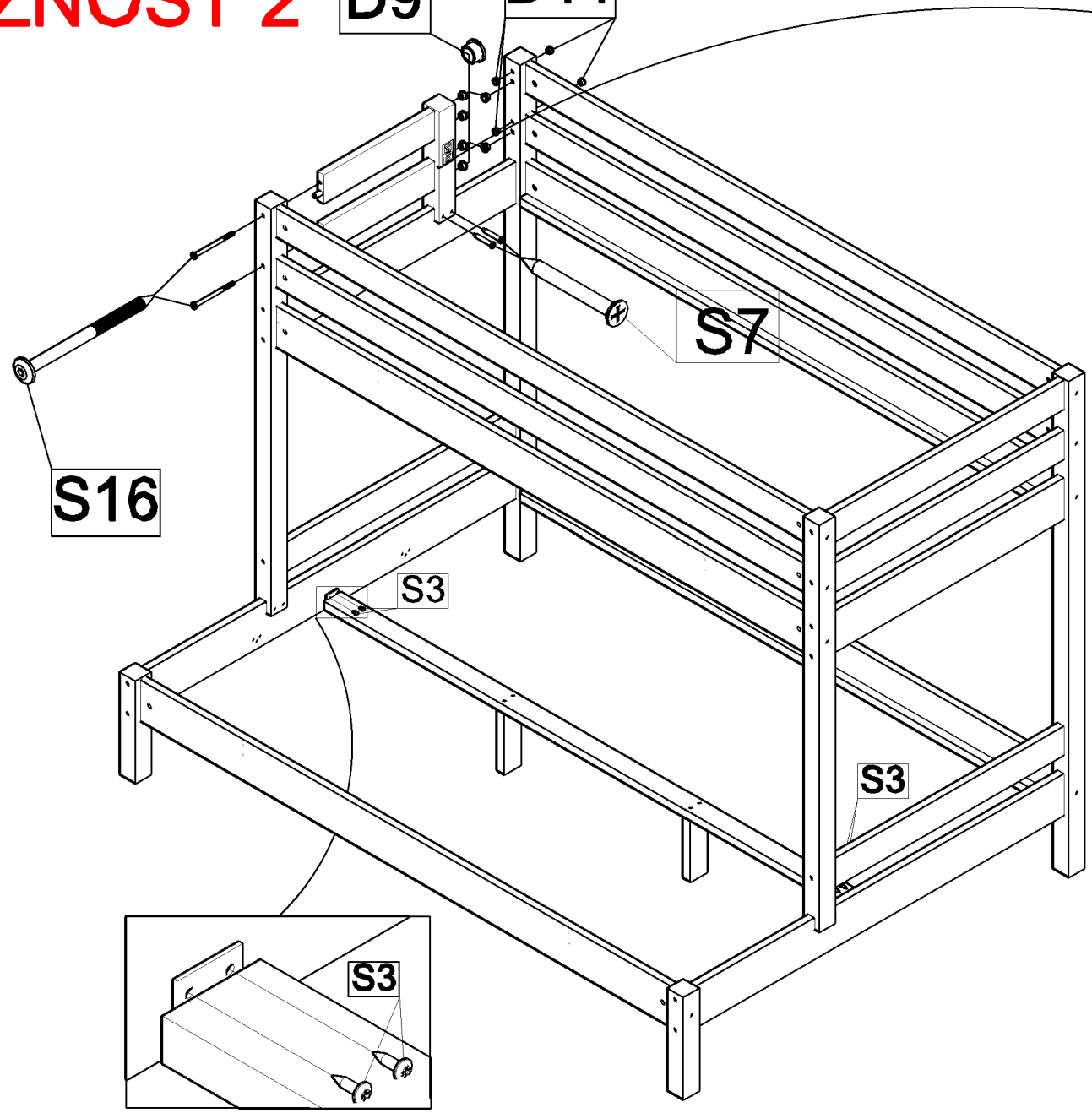



6+

Maximální umístění horní části matrace

Maximální tloušťka matrace 18 cm

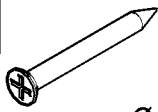
19a/21

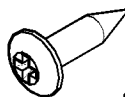
- | | | |
|-----|---|-----|
| S16 |  | x 2 |
| | Ø6,3 x 110 | |
| S7 |  | x 2 |
| | Ø4 x 50 | |
| D11 |  | x 4 |
| | Ø8 | |
| D9 |  | x 6 |
| | Ø10 | |
| S3 |  | x 4 |
| | Ø3,5x 16 | |

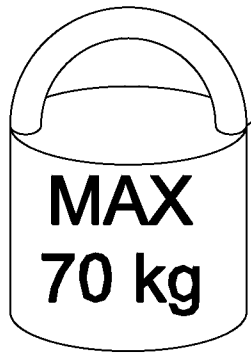

**MAX
70 kg**

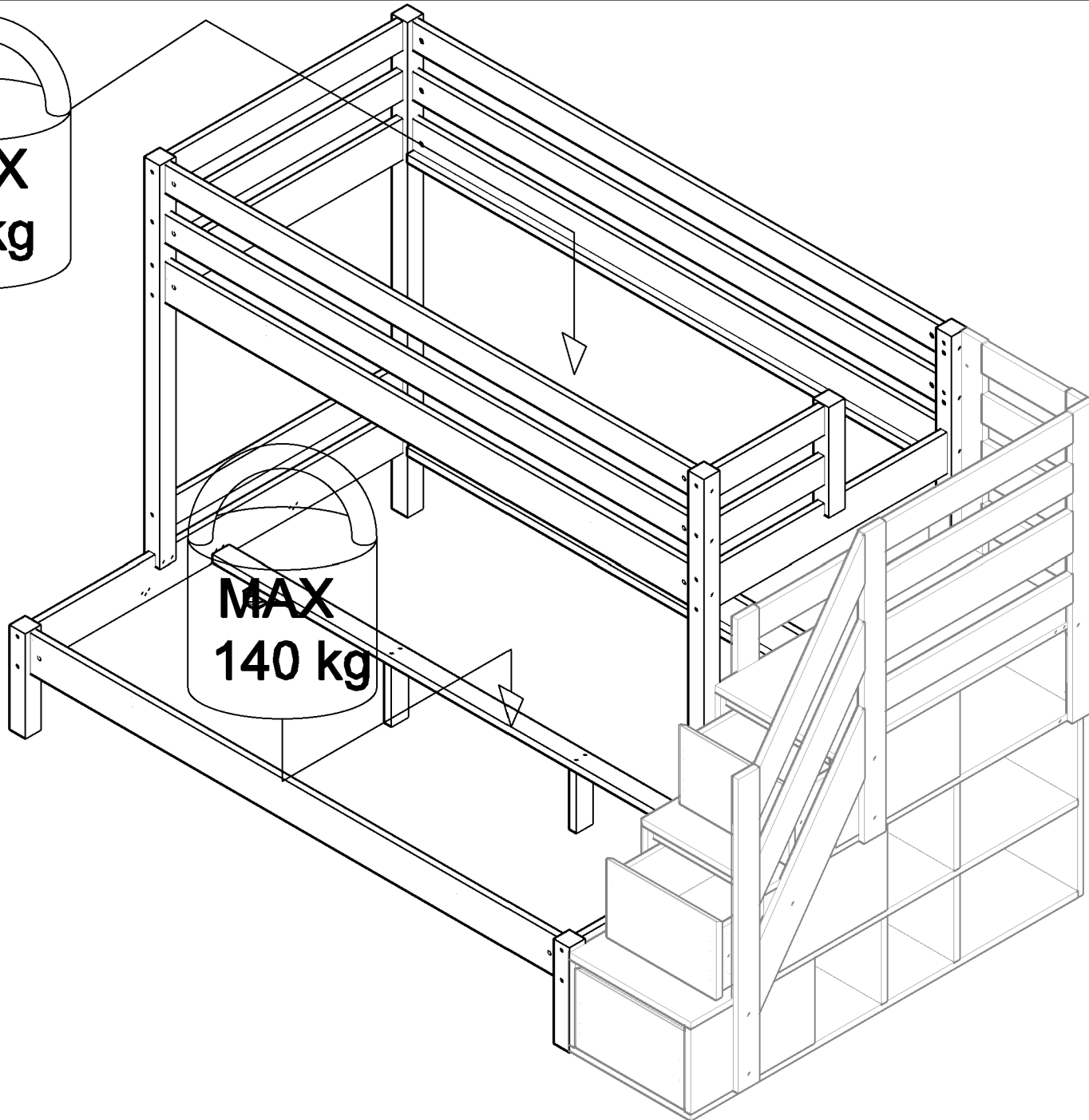

**MAX
140 kg**

